

| ITEM# | A | B | C | D | E | WEIGHT |
|--------------------------|------|-----|------|------|------|--------|
| FR 042.0 | 3.72 | .50 | 3.60 | 1.75 | 1.98 | 1.00 |
| FR 042.10 | 3.72 | .50 | 3.60 | 1.75 | 2.35 | 1.03 |
| FR 042.2 THREADED CAP | | | | | | .11 |

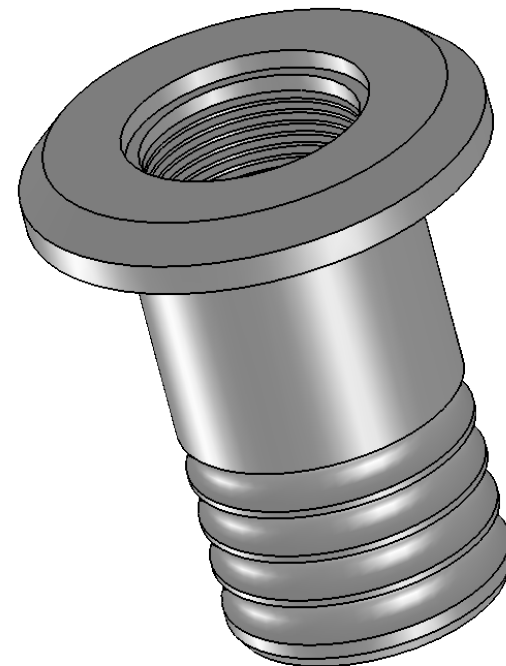

PROPRIETARY AND CONFIDENTIAL

THE INFORMATION CONTAINED IN THIS DRAWING IS THE SOLE PROPERTY OF FRASER BRONZE FOUNDRY, INC. ANY REPRODUCTION IN PART OR AS A WHOLE WITHOUT THE WRITTEN PERMISSION OF FRASER BRONZE FOUNDRY, INC. IS PROHIBITED.

| | | | | |
|-------------|---------|-----------------------------|-----------|--------------|
| | | UNLESS OTHERWISE SPECIFIED: | NAME | DATE |
| | | DIMENSIONS ARE IN INCHES | DRAWN | KJF 12/23/14 |
| | | TOLERANCES: | CHECKED | |
| | | FRACTIONAL ± | ENG APPR. | |
| | | ANGULAR: MACH ± BEND ± | MFG APPR. | |
| | | TWO PLACE DECIMAL ± | Q.A. | |
| | | THREE PLACE DECIMAL ± | COMMENTS: | |
| | | ITEM# | | |
| | | FR 042.2 & FR 042.10 | | |
| | | MATERIAL | | |
| | | 713 ALUMINUM | | |
| NEXT ASSY | USED ON | FINISH | | |
| APPLICATION | | DO NOT SCALE DRAWING | | |

FRASER BRONZE FOUNDRY, INC

TITLE:

HOSE DECK FILL

SIZE DWG. NO. REV
A FR 042.0-.1

SCALE: 1:2 WEIGHT: SHEET 1 OF 1