

ITEM #	A	B	C	D	E	F	MOUNTING HOLES
FR 020.25	3.00	7.50	6.00	1.20	.75	.75	4
FR 020.26	6.00	11.00	9.50	1.36	.74	.81	8
FR 020.27	8.00	13.50	11.75	1.51	.82	.81	8
FR 020.28	10.00	16.00	14.25	1.58	1.00	1.00	12
FR 020.29	12.00	19.00	17.00	2.06	1.10	1.00	12

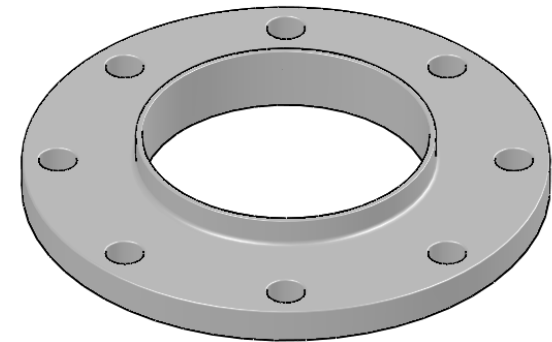
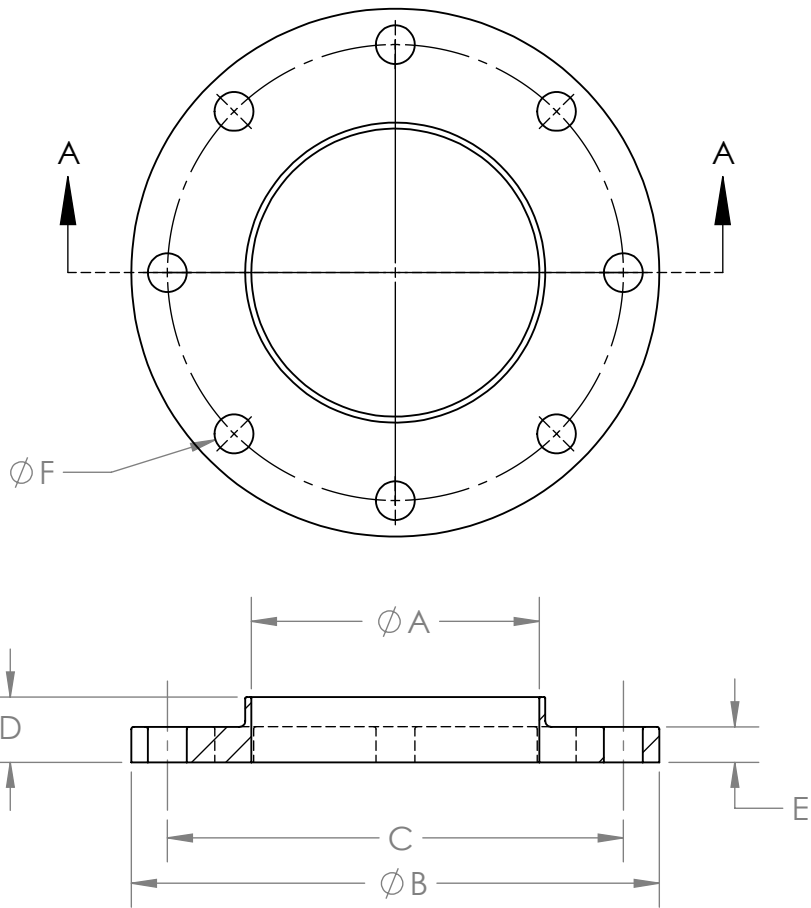

SECTION A-A

PROPRIETARY AND CONFIDENTIAL

THE INFORMATION CONTAINED IN THIS DRAWING IS THE SOLE PROPERTY OF FRASER BRONZE FOUNDRY, INC. ANY REPRODUCTION IN PART OR AS A WHOLE WITHOUT THE WRITTEN PERMISSION OF FRASER BRONZE FOUNDRY, INC. IS PROHIBITED.

		UNLESS OTHERWISE SPECIFIED:		NAME	DATE	FRASER BRONZE FOUNDRY, INC	
		DIMENSIONS ARE IN INCHES TOLERANCES: FRACTIONAL \pm ANGULAR: MACH \pm BEND \pm TWO PLACE DECIMAL \pm THREE PLACE DECIMAL \pm		DRAWN	KJF	12/23/14	TITLE:
		ITEM#		CHECKED			WELD FLANGE
		MATERIAL A356 ALUMINUM		ENG APPR.			
		FINISH		MFG APPR.			SIZE DWG. NO. REV
NEXT ASSY	USED ON			Q.A.			A FR 020.25-.29
APPLICATION		DO NOT SCALE DRAWING		COMMENTS:			SCALE: 1:4 WEIGHT: SHEET 1 OF 1