

ITEM#	A	B	C	D	E	F	G	WEIGHT
FR 063.1	4.23	2.21	2.68	3.28	1.26	.25	N/A	.82
FR 064.1	5.53	3.50	3.97	4.65	1.24	.31	5.00	1.40

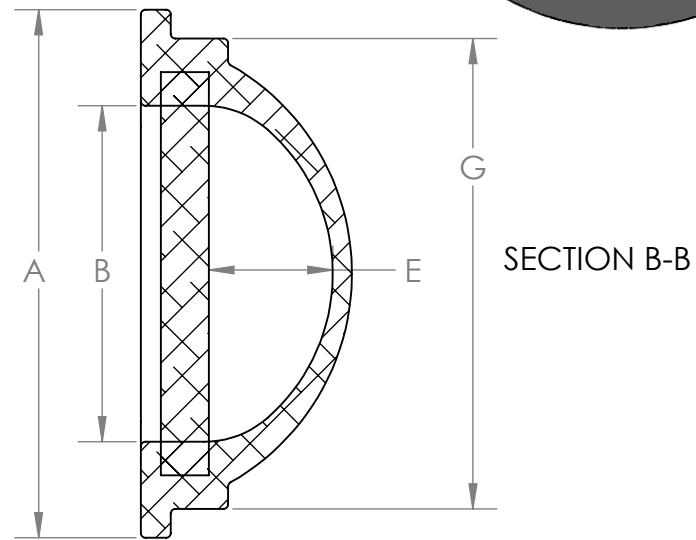
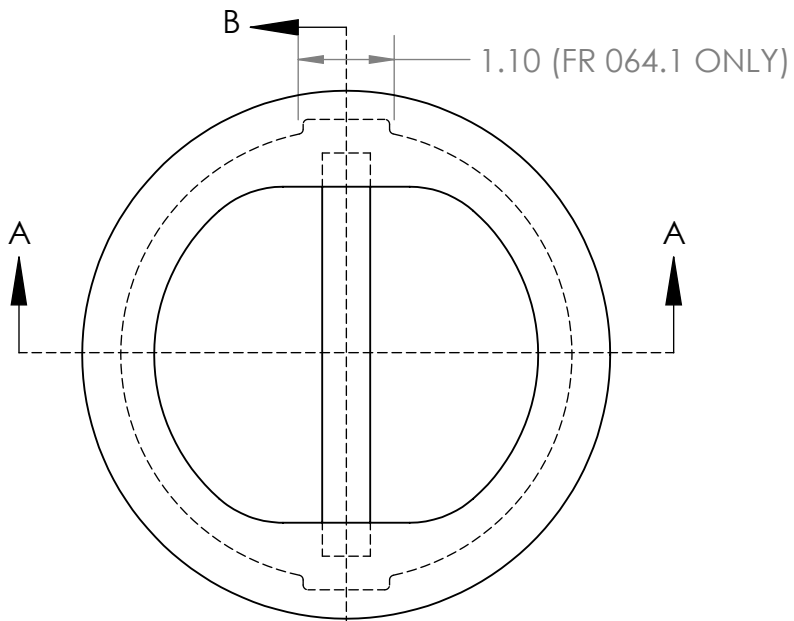
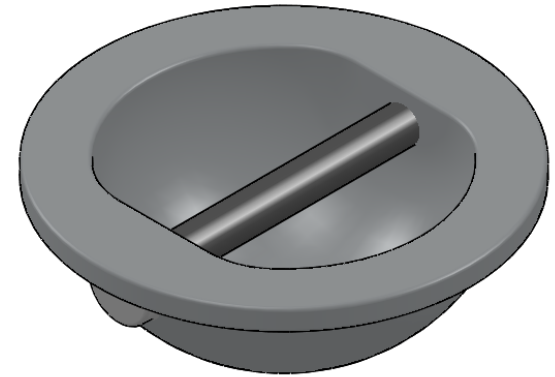
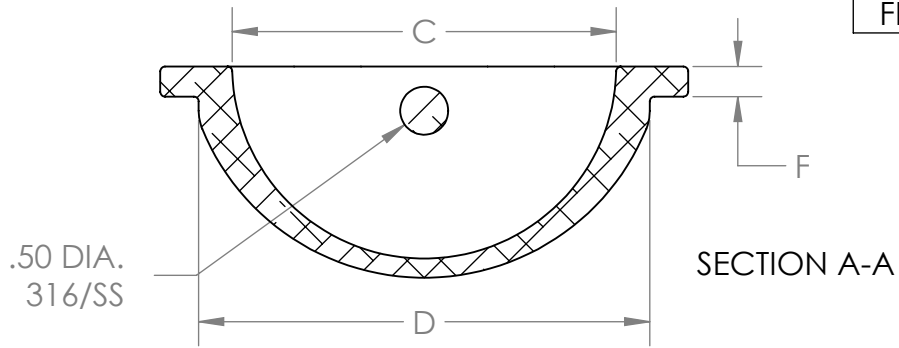

PROPRIETARY AND CONFIDENTIAL

THE INFORMATION CONTAINED IN THIS DRAWING IS THE SOLE PROPERTY OF FRASER BRONZE FOUNDRY, INC. ANY REPRODUCTION IN PART OR AS A WHOLE WITHOUT THE WRITTEN PERMISSION OF FRASER BRONZE FOUNDRY, INC. IS PROHIBITED.

		UNLESS OTHERWISE SPECIFIED:	NAME	DATE
		DIMENSIONS ARE IN INCHES	DRAWN	KJF
		TOLERANCES:	CHECKED	12/23/14
		FRACTIONAL	ENG APPR.	
		ANGULAR: MACH BEND	MFG APPR.	
		TWO PLACE DECIMAL	Q.A.	
		THREE PLACE DECIMAL	COMMENTS:	
		ITEM#	FR 063.1 & FR 064.1	
		MATERIAL	A356 ALUMINUM	
NEXT ASSY	USED ON	FINISH		
APPLICATION		DO NOT SCALE DRAWING		

FRASER BRONZE FOUNDRY, INC

TITLE:

TIE POCKET SS

SIZE	DWG. NO.	REV
A	FR 063.1 064.1	

SCALE: 1:2	WEIGHT:	SHEET 1 OF 1
------------	---------	--------------