

ITEM #	A
FR 002.35	.75" TAPER BORE
FR 002.36	1.00" STRAIGHT BORE

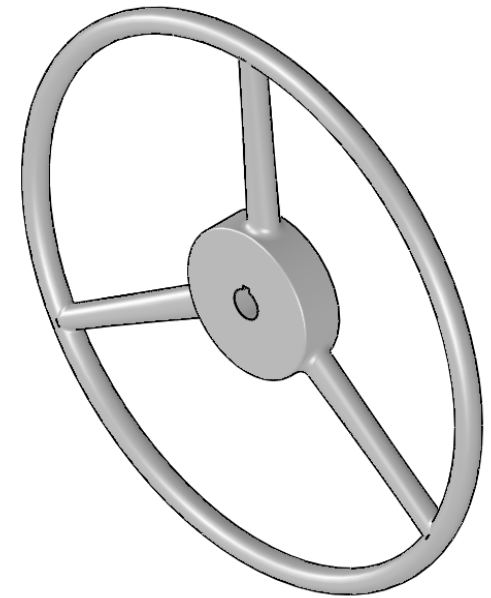
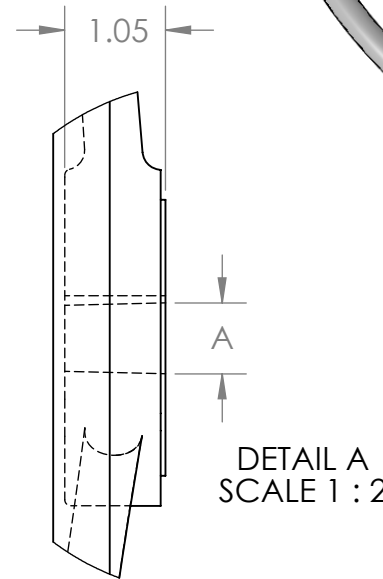
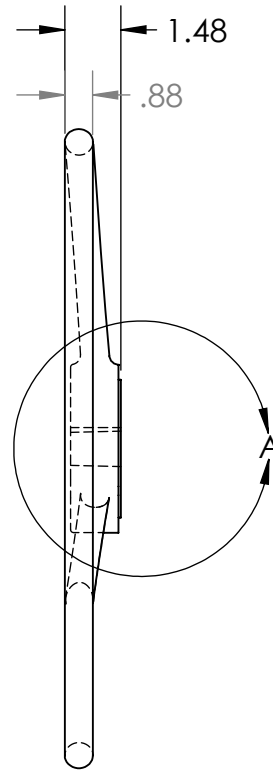
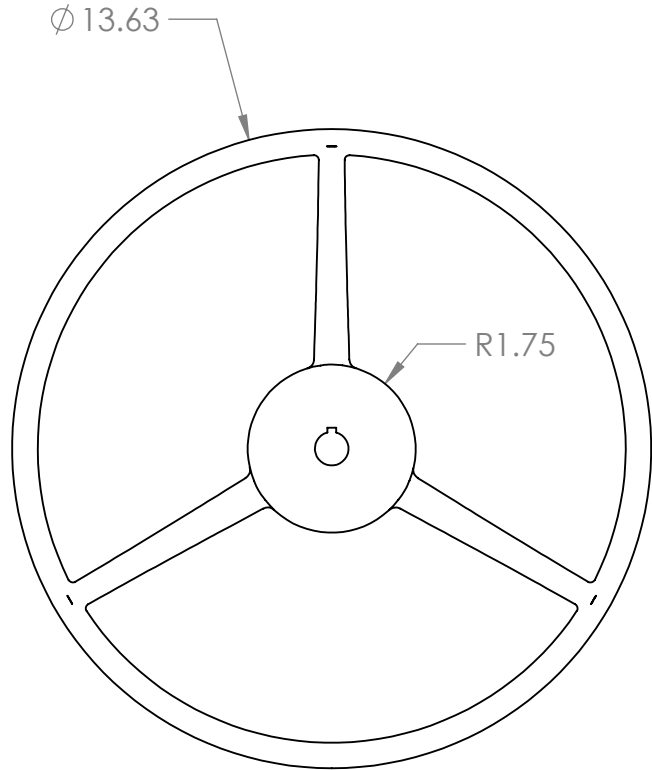

PROPRIETARY AND CONFIDENTIAL

THE INFORMATION CONTAINED IN THIS DRAWING IS THE SOLE PROPERTY OF FRASER BRONZE FOUNDRY, INC. ANY REPRODUCTION IN PART OR AS A WHOLE WITHOUT THE WRITTEN PERMISSION OF FRASER BRONZE FOUNDRY, INC. IS PROHIBITED.

		UNLESS OTHERWISE SPECIFIED:	NAME	DATE
		DIMENSIONS ARE IN INCHES	DRAWN	KJF 12/23/14
		TOLERANCES:	CHECKED	
		FRACTIONAL ±	ENG APPR.	
		ANGULAR: MACH ± BEND ±	MFG APPR.	
		TWO PLACE DECIMAL ±	Q.A.	
		THREE PLACE DECIMAL ±	COMMENTS:	
		ITEM#		
		MATERIAL		
		A356 ALUMINUM		
		FINISH		
NEXT ASSY	USED ON			
APPLICATION		DO NOT SCALE DRAWING		

FRASER BRONZE FOUNDRY, INC

TITLE:

14" HANDWHEEL

SIZE	DWG. NO.	REV
A	FR 020.35-.36	

SCALE: 1:8	WEIGHT: 3.17	SHEET 1 OF 1
------------	--------------	--------------