

ITEM #	A	B	C	D	E	F	G	H	I	WEIGHT
FR 014.0	15.00	5.04	2.75	8.25	5.63	1.00	1.40	1.95	1.06	1.58
FR 015.0	22.38	6.56	3.53	10.70	7.00	0.00	2.15	3.12	1.42	5.43

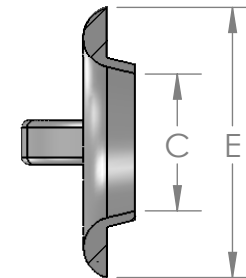
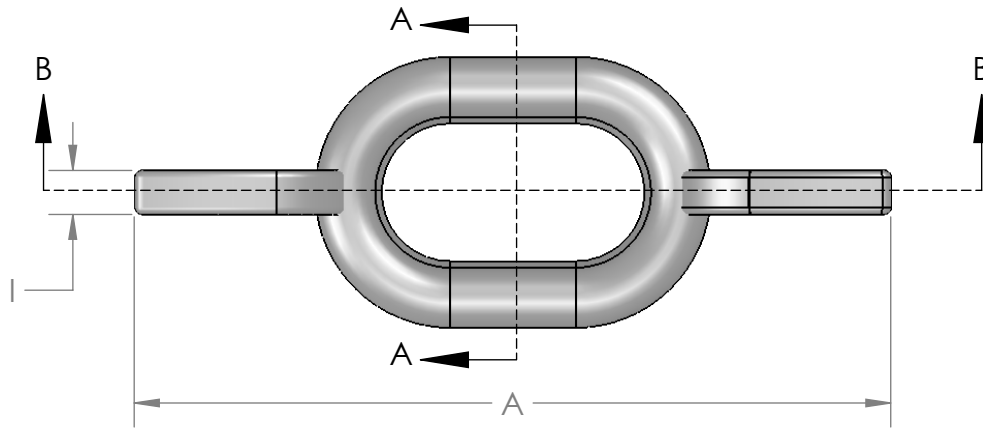
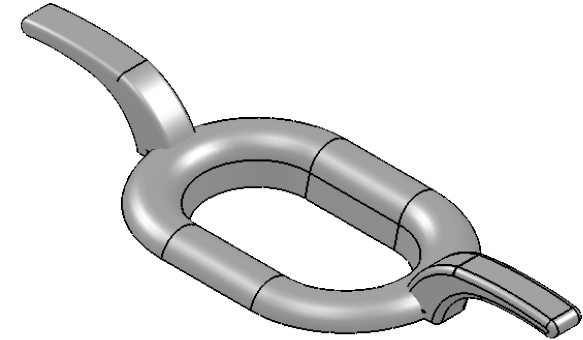
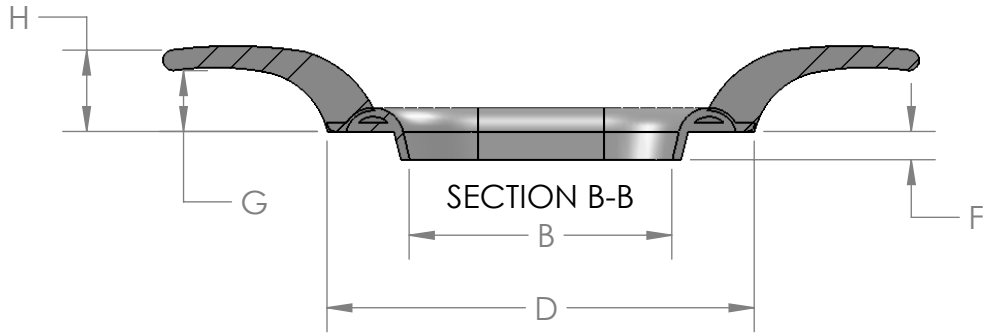

SECTION A-A

PROPRIETARY AND CONFIDENTIAL

THE INFORMATION CONTAINED IN THIS DRAWING IS THE SOLE PROPERTY OF FRASER BRONZE FOUNDRY, INC. ANY REPRODUCTION IN PART OR AS A WHOLE WITHOUT THE WRITTEN PERMISSION OF FRASER BRONZE FOUNDRY, INC. IS PROHIBITED.

		UNLESS OTHERWISE SPECIFIED:	NAME	DATE
		DIMENSIONS ARE IN INCHES	DRAWN	KJF
		TOLERANCES:	CHECKED	12/23/14
		FRACTIONAL ±	ENG APPR.	
		ANGULAR: MACH ± BEND ±	MFG APPR.	
		TWO PLACE DECIMAL ±	Q.A.	
		THREE PLACE DECIMAL ±	COMMENTS:	
	ITEM#	MATERIAL	A356 ALUMINUM	
	NEXT ASSY	USED ON	FINISH	
	APPLICATION		DO NOT SCALE DRAWING	

FRASER BRONZE FOUNDRY, INC

TITLE:

**BULWARK CHOCK
W/ HORNS**

SIZE	DWG. NO.	REV
A	FR 014.0 - 015.0	

SCALE: 1:4	WEIGHT:	SHEET 1 OF 1
------------	---------	--------------